

# Instructions



## TDSUSBF USB 2.0 Compliance Test Fixture 071-1063-02

This document applies to firmware version X.XX and above.

### **Warning**

The servicing instructions are for use by qualified personnel only. To avoid personal injury, do not perform any servicing unless you are qualified to do so. Refer to all safety summaries prior to performing service.

[www.tektronix.com](http://www.tektronix.com)



071106302

Copyright © Tektronix, Inc. All rights reserved. Licensed software products are owned by Tektronix or its subsidiaries or suppliers, and are protected by national copyright laws and international treaty provisions.

Tektronix products are covered by U.S. and foreign patents, issued and pending. Information in this publication supercedes that in all previously published material. Specifications and price change privileges reserved.

TEKTRONIX and TEK are registered trademarks of Tektronix, Inc.

## **Contacting Tektronix**

Tektronix, Inc.  
14200 SW Karl Braun Drive  
P.O. Box 500  
Beaverton, OR 97077  
USA

For product information, sales, service, and technical support:

- In North America, call 1-800-833-9200.
- Worldwide, visit [www.tektronix.com](http://www.tektronix.com) to find contacts in your area.

## Warranty 5

Tektronix warrants that this product will be free from defects in materials and workmanship for a period of three (3) months from the date of shipment. If any such product proves defective during the warranty period, Tektronix, at its option, either will repair the defective product without charge for parts and labor, or will provide a replacement in exchange for the defective product. Parts, modules and replacement products used by Tektronix for warranty work may be new or reconditioned to like new performance. All replaced parts, modules and products become the property of Tektronix.

In order to obtain service under this warranty, Customer must notify Tektronix of the defect before the expiration of the respective warranty period and make suitable arrangements for the performance of service. Customer shall be responsible for packaging and shipping the defective product to the service center designated by Tektronix, with shipping charges prepaid. Tektronix shall pay for the return of the product to Customer if the shipment is to a location within the country in which the Tektronix service center is located. Customer shall be responsible for paying all shipping charges, duties, taxes, and any other charges for products returned to any other locations.

This warranty shall not apply to any defect, failure or damage caused by improper use or improper or inadequate maintenance and care. Tektronix shall not be obligated to furnish service under this warranty a) to repair damage resulting from attempts by personnel other than Tektronix representatives to install, repair or service the product; b) to repair damage resulting from improper use or connection to incompatible equipment; c) to repair any damage or malfunction caused by the use of non-Tektronix supplies; or d) to service a product that has been modified or integrated with other products when the effect of such modification or integration increases the time or difficulty of servicing the product.

THIS WARRANTY IS GIVEN BY TEKTRONIX WITH RESPECT TO THE PRODUCT IN LIEU OF ANY OTHER WARRANTIES, EXPRESS OR IMPLIED. TEKTRONIX AND ITS VENDORS DISCLAIM ANY IMPLIED WARRANTIES OF MERCHANTABILITY OR FITNESS FOR A PARTICULAR PURPOSE. TEKTRONIX' RESPONSIBILITY TO REPAIR OR REPLACE DEFECTIVE PRODUCTS IS THE SOLE AND EXCLUSIVE REMEDY PROVIDED TO THE CUSTOMER FOR BREACH OF THIS WARRANTY. TEKTRONIX AND ITS VENDORS WILL NOT BE LIABLE FOR ANY INDIRECT, SPECIAL, INCIDENTAL, OR CONSEQUENTIAL DAMAGES IRRESPECTIVE OF WHETHER TEKTRONIX OR THE VENDOR HAS ADVANCE NOTICE OF THE POSSIBILITY OF SUCH DAMAGES.



# General Safety Summary

Review the following safety precautions to avoid injury and prevent damage to this product or any products connected to it. To avoid potential hazards, use this product only as specified.

*Only qualified personnel should perform service procedures.*

While using this product, you may need to access other parts of the system. Read the *General Safety Summary* in other system manuals for warnings and cautions related to operating the system.

## **To Avoid Fire or Personal Injury**

**Use Proper Power Cord.** Use only the power cord specified for this product and certified for the country of use.

**Connect and Disconnect Properly.** Connect the probe output to the measurement instrument before connecting the probe to the circuit under test. Disconnect the probe input and the probe ground from the circuit under test before disconnecting the probe from the measurement instrument.

**Observe All Terminal Ratings.** To avoid fire or shock hazard, observe all ratings and markings on the product. Consult the product manual for further ratings information before making connections to the product.

**Use Proper AC Adapter.** Use only the AC adapter specified for this product.

**Use Proper Fuse.** Use only the fuse type and rating specified for this product.

**Do Not Operate With Suspected Failures.** If you suspect there is damage to this product, have it inspected by qualified service personnel.

**Do Not Operate in Wet/Damp Conditions.**

**Do Not Operate in an Explosive Atmosphere.**

**Keep Product Surfaces Clean and Dry.**

**Symbols and Terms**

**Terms in this Manual.** These terms may appear in this manual:



---

**WARNING.** *Warning statements identify conditions or practices that could result in injury or loss of life.*

---



---

**CAUTION.** *Caution statements identify conditions or practices that could result in damage to this product or other property.*

---

**Terms on the Product.** These terms may appear on the product:

DANGER indicates an injury hazard immediately accessible as you read the marking.

WARNING indicates an injury hazard not immediately accessible as you read the marking.

CAUTION indicates a hazard to property including the product.

**Symbols on the Product.** The following symbols may appear on the product:



CAUTION  
Refer to Manual



Double  
Insulated

# Environmental Considerations

This section provides information about the environmental impact of the product.

## Product End-of-Life Handling

Observe the following guidelines when recycling an instrument or component:

**Equipment Recycling.** Production of this equipment required the extraction and use of natural resources. The equipment may contain substances that could be harmful to the environment or human health if improperly handled at the product's end of life. In order to avoid release of such substances into the environment and to reduce the use of natural resources, we encourage you to recycle this product in an appropriate system that will ensure that most of the materials are reused or recycled appropriately.

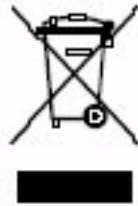

The symbol shown to the left indicates that this product complies with the European Union's requirements according to Directive 2002/96/EC on waste electrical and electronic equipment (WEEE). For information about recycling options, check the Support/Service section of the Tektronix Web site ([www.tektronix.com](http://www.tektronix.com)).

## Restriction of Hazardous Substances

This product has been classified as Monitoring and Control equipment, and is outside the scope of the 2002/95/EC RoHS Directive. This product is known to contain lead, cadmium, mercury, and hexavalent chromium.





# TDSUSBF Test Fixture

The TDSUSBF is a test fixture used to take measurements of the USB 2.0 interface bus. Tests include signal quality, inrush, droop, receiver sensitivity, and impedance measurement, all mandatory for USB 2.0 compliance. The fixture can be used with user-written software or with Tektronix-supplied software (TDSUSBS).

## Accessories

The following accessories are included with the fixture. Refer to the *Replaceable Parts List* on page 9 for part numbers when ordering replacement parts.

- Instructions
- Adapter—adapts an A male plug to a B male plug
- Power supply
- Power cord—North American, 250 V Standard - Options available:
  - Option A1—Universal European 250 V, 50 Hz
  - Option A2—United Kingdom 240 V, 50 Hz
  - Option A3—Australian 250 V, 50 Hz
  - Option A5—Switzerland 250 V, 50 Hz
  - Option AC—China 250 V, 50 Hz
  - Option 99—No power cord
- Short USB cable

## Test Equipment

The following test equipment is recommended for use with the fixture:

- TDS8000 Oscilloscope with an 80E04 TDR sampling module
- P6248 1.7 GHz Differential Probe
- P6245 1.5 GHz 10X Probe (3)
- TCP202 Current Probe
- DG2040 Data Generator or AWG610 Arbitrary Waveform Generator
- High quality SMA cables and attenuators

## Installation

To use the test fixture, refer to Figure 1 on page 5, and do the following:



---

**CAUTION.** To prevent damage to the test fixture, always work at a static-approved workstation when handling the fixture.

---

1. Set the fixture on a nonconductive work surface.



---

**CAUTION.** To prevent damage to TDR heads, the board must be powered on in the following sequence:

---

2. Connect the power supply cable to the DC Power In jack located at the top of the board.
3. Connect the line cord to the power supply and to an appropriate line source.
4. Check that the power-on LED lights. If it does not, remove the power supply cable from the DC Power In jack, and check for shorts.
5. Put switch S6 in the INIT position. The INIT status LED lights.
6. Connect the board for specific tests as described in Table 1 on page 6.
7. Set the DUT (Device Under Test) to the proper test state. (See note.)

---

**NOTE.** For example, in a TDR upstream test, the DUT must be configured to SE0\_NAK test mode. Otherwise, DUT transmissions can damage test equipment connected to the fixture.

*For all TDR tests, you should verify with a DMM that the DC bias level is less than 10 mV from D+ to ground and from D- to ground.*

---

8. Put switch S6 in the TEST position. The TEST status LED lights.
9. Perform the test steps as required for your specific test.
10. When you are finished testing, put switch S6 in the INIT position and disconnect the power supply cable from the DC Power In jack.

## Connections and Switch Settings

Use Figure 1 on page 5 and Table 1 on page 6 to prepare the fixture for specific tests.

For most tests, the following oscilloscope configuration is recommended:

CH 1—Single ended probe connected to D+

CH 2—Single ended probe connected to D-

CH 3—Adjacent channel trigger source

### Switch S6 (Init/Test)

The initialize and test switch (S6) is a two-position switch used to initialize and test the following:

- Device high speed TDR
- Device high speed receiver sensitivity
- Device high speed signal quality

---

**NOTE.** *The device high-speed signal quality section of the test fixture is also used for downstream low-speed/full-speed signal quality testing. When testing downstream low-speed/full-speed signal quality, S6 remains in the INIT position.*

---

In the initialize position, the signal is routed through the fixture, from the input to the output connectors. In the test position, the signal is passed from the DUT to the SMA connectors on the fixture, to be connected to test equipment, such as a TDR.

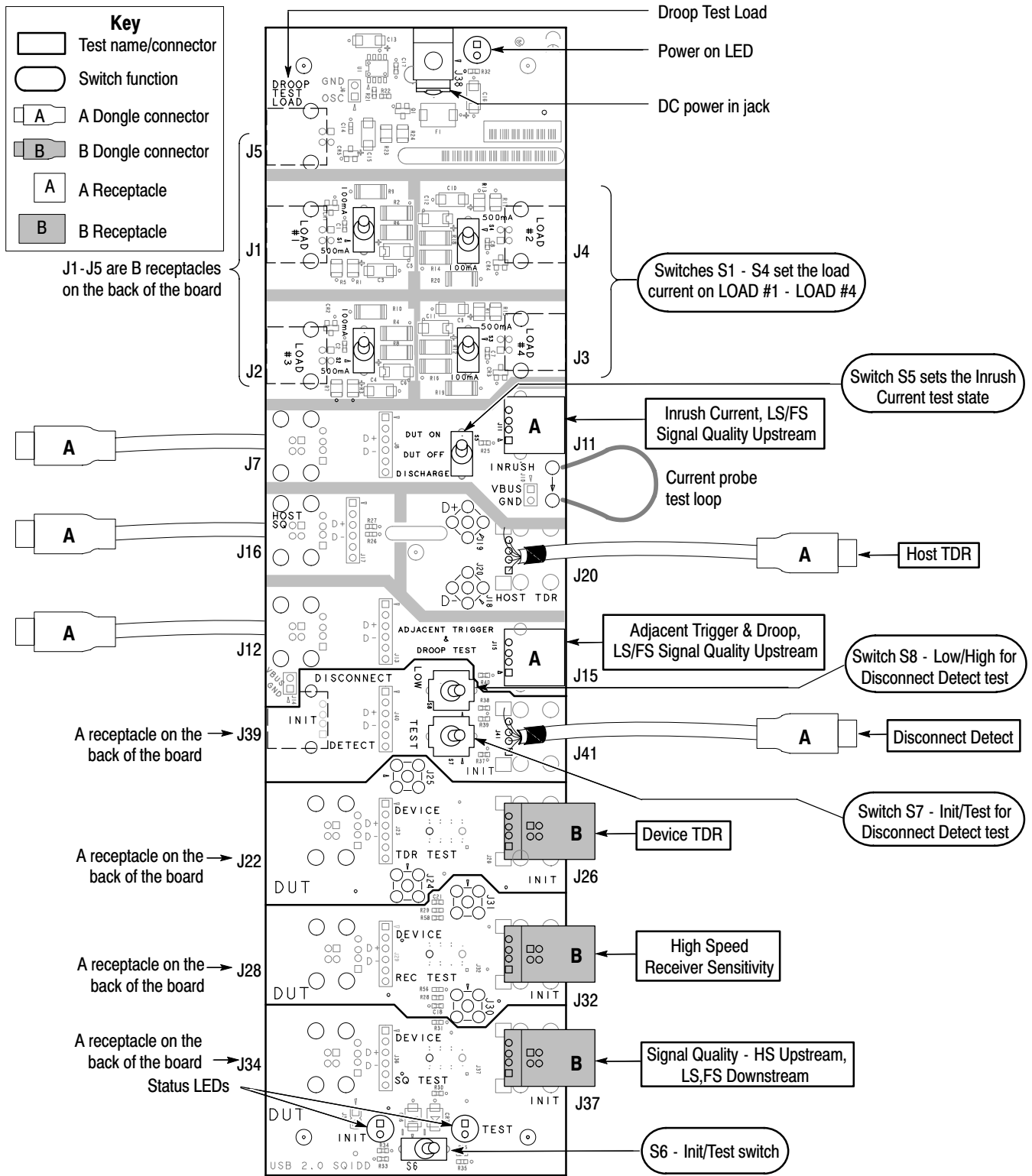

Figure 1: Fixture connections and switch functions

**Signal Connections** Use Table 1 and Figure 1 on page 5 to prepare the fixture for specific tests.

**Table 1: USB signal connections and switch settings**

Test <sup>1</sup>	Upstream (Host) connector number/type	Downstream (DUT) connector number/type	Switch Number and Setting
Host TDR <sup>2</sup>	J20 / A Dongle	N/A	N/A
Device TDR <sup>2</sup>	J26 / B receptacle	J22 / A receptacle	S6 switch to INIT, and then TEST
Host Signal Quality	J16 / A Dongle	N/A	N/A
HS Signal Quality Upstream	J37 / B receptacle	J34 / A receptacle	S6 switch to INIT, and then TEST
LS, FS Signal Quality Upstream	J11, J15 / A receptacle	J7, J12 / A Dongle	S5 switch to On
LS, FS Signal Quality Downstream	J37 / B receptacle	J34 / A receptacle	S6 switch to INIT, and then TEST
HS Receiver Sensitivity <sup>2</sup>	J32 / B receptacle	J28 / A receptacle	S6 switch to INIT, and then TEST
Disconnect Detection	J41 / A Dongle	J39 / A receptacle	S7 switch in INIT position, and then TEST S8 switch in High position, and then Low
Adjacent Trigger and Droop	J12 / A Dongle	J15 / A receptacle <sup>3</sup>	N/A
Inrush Current	J11/ A receptacle	J7 / A Dongle	S5 to Off, then Discharge, and then On

<sup>1</sup> **LS = Low Speed, FS = Full Speed, HS = High Speed**

<sup>2</sup> **See Table 2 for SMA connections**

<sup>3</sup> **Connected to a load using a USB cable**

**SMA Connections** The SMA connectors on the fixture are used to connect additional test equipment to the test fixture.

Table 2 lists the details of where the SMA connectors are used. See Figure 1 on page 5 for connector locations.

**Table 2: SMA connections**

Test	Connector number and connection	Connector number and connection
High Speed Receiver Sensitivity	J31 (D+) to DG2040, Ch 0	J30 (D-) to DG2040, Ch 1
High Speed Device TDR	J24 to TDR Sampling Module, Ch 1	J25 to TDR Sampling Module, Ch 2
High Speed Host TDR	J19 to TDR Sampling Module, Ch 1	J18 to TDR Sampling Module, Ch 2

**Load Connections**

Two types of loads (passive and active) are provided on the fixture for you to include in different tests and configurations. Four separate passive loads, #1 to #4, are switchable from 100 mA, off, and 500 mA.



**WARNING.** To avoid personal injury, do not touch the load resistors when using the 500 mA load positions. The load resistors can become very hot.

The droop test load is an active load that switches between an open circuit condition and 100 mA, at approximately a 2 Hz rate.

All loads connect via B-style receptacles that are mounted on the back side of the test fixture.

**NOTE.** Switch numbers do not follow load numbers. For example, Switch 4 controls Load #2. See Table 3 for the correct switch/load combinations.

Use Table 3 and Figure 1 on page 5 to configure loads for specific tests.

**Table 3: Load connections and switch settings**

Load number	Connector number/type	Switch number	Switch positions
#1	J1 / B receptacle	S1	100 mA / off / 500 mA
#2	J4 / B receptacle	S4	100 mA / off / 500 mA
#3	J2 / B receptacle	S3	100 mA / off / 500 mA
#4	J3 / B receptacle	S2	100 mA / off / 500 mA
Droop test	J5 / B receptacle	N/A	0 mA to 100 mA at ~2 Hz rate

## Specifications

This section contains the specifications of the TDSUSBF Test Fixture. All specifications are guaranteed unless noted as typical. Typical specifications are provided for your convenience, but are not guaranteed.

**Table 4: Specifications**

Specification	Description
Input voltage rating	+5.0 VDC, $\pm 0.25$ V
Power Consumption, Typical	1 W
Fuse Rating	0.5 A, 60 V, Polyswitch resettable fuse
Operating Temperature	+15 °C to +35 °C (59 °F to 95 °F)

**Table 5: Certifications and compliances**

Category	Standards or description
EC Declaration of Conformity - EMC	Meets intent of Directive 89/336/EEC for Electromagnetic Compatibility. Compliance was demonstrated to the following specifications as listed in the Official Journal of the European Communities: EN 61326                      EMC requirements for Class A electrical equipment for measurement, control and laboratory use. <sup>1</sup> IEC 61000-4-2                Electrostatic discharge immunity (Performance criterion D) IEC 61000-4-3                RF electromagnetic field immunity (Performance criterion A) IEC 61000-4-4                Electrical fast transient / burst immunity (Performance criterion B) IEC 61000-4-5                Power line surge immunity (Performance criterion B) IEC 61000-4-6                Conducted RF immunity (Performance criterion A) IEC 61000-4-11              Voltage dips and interruptions immunity (Performance criterion B) EN 61000-3-2                AC power line harmonic emissions
Australia/New Zealand Declaration of Conformity - EMC	Complies with EMC provision of Radiocommunications Act per the following standard(s): AS/NZS 2064.1/2              Industrial, Scientific, and Medical Equipment: 1992
FCC Compliance	Emissions comply with FCC Code of Federal Regulations 47, Part 15, Subpart B, Class A Limits.

<sup>1</sup> Emissions which exceed the levels required by this standard may occur when this equipment is connected to a test object.



## Replaceable Parts List

This section contains a list of the replaceable parts for the fixture. Use this list to identify and order replacement parts.

### Replaceable Parts

Part ID	Tektronix part number	Serial no. effective	Serial no. discont'd	Qty	Name & description	Mfr. code	Mfr. part number
A dongle	174-4662-00			5	CABLE ASSY,SP:USB,TYPE A CONN TO STRIPPED END		174-4662-00
Short USB cable	174-5197-00			1	CABLE ASSY,5 INCH USB 2.0 I/O CABLE		174-5197-00
A receptacle	131-6277-00			6	CONN,RIBBON:PCB,USB, SERIES A,FEMALE,RTANG, 1 X 4,2.5MM CTR,7.01MM H X 2.29MM TAIL,PALLADIUM	00779	787616-2
B receptacle	131-7307-00			8	CONN:PCB,USB,SERIES B,FEMALE,RTANG, 1 X 4,2.5 MM CTR,0.433" H X 0.110 TAIL,SHLD,GOLD F	TK0EM	67068-0000
S1-5	260-2767-00			5	SWITCH,TOGGLE:SPDT,ON-OFF-ON,MEDIUM ACTUATOR,THREADED BUSHING,PC MOUNT THRU-HOLE,SILVER CONTACT	09353	T103SHCQE
S6	260-2769-00			1	SWITCH,TOGGLE:SPDT,3A AT 28VDC,ON-NONE-ON,STD 0.370" HIGH ACTUATOR,THREADED BUSHING,PCB TERMIN	09353	T101SHCQE
S7, 8	260-2766-00			2	SWITCH,TOGGLE:DPDT,ON-NONE-ON,MEDIUM ACTUATOR,THREADED BUSHING,PC MOUNT THRU-HOLE,SILVER CONTA	09353	T201SHCQE
F1	159-0412-00			1	FUSE,THRM,CHIP:SELF RESETTING FUSE,0.5A HOLD,1.0A TRIP,60V MAX,SMD050,T&R,	06090	SMD050-2
LEDs	150-1059-00			3	DIODE,OPTO:LED,RED,626NM,20MCD AT 10MA,35 DEG VIEW ANGLE,HLMP-3316,T-1 3/4	50434	HLMP-3316
K1-3	148-0270-00			3	RELAY, ARMATURE:2FORMC, LATCH, RF 50 OHM,INS LSS 0.2DB@1GHZ, 28V, 0.25A, COIL 5VDC, 61OHM, .30H	11532	RF170-5
Power supply	119-5883-00			1	POWER SUPPLY:EXTERNAL,DESKTOP,7.5W,100-250VAC (-10%, +6%) 47-63HZ IN,5VDC 1.5A OUT,REG OUT,6	14310	PW10DEA0503F01
Power cord	161-0104-00			1	CABLE ASSY:3,18 AWG, 98 L, 250V/10A, IEC320, NEMA 15-5P, WITH CORD GRIP, US	S3109	ORDER BY DESCRIPTION
	161-0104-06			1	CA ASSY,PWR:3,1.0MM SQ,250V/10A,2.5 METER,RTANG,IEC320,RCPT,EUROPEAN	TK1373	ORDER BY DESCRIPTION
	161-0104-07			1	CA ASSY,PWR:3,1.0MM SQ,240V/10A,2.5 METER, RTANG,IEC320,RCPT X 13A,FUSED,UK PLUG,(13A FUSE),U	TK2541	ORDER BY DESCRIPTION
	161-0104-05			1	CA ASSY,PWR:3,1.0MM SQ,250V/10A,2.5 METER,RTANG,IEC320,RCPT,AUSTRALIA	TK1373	161-0104-05
	161-0167-00			1	CA ASSY,PWR:3,0.75MM SQ,250V/10A,2.5 METER,RTANG,IEC320,RCPT,SWISS,NO CORD GRIP	S3109	ORDER BY DESCRIPTION
161-0306-00			1	CA ASSY,PWR:3,1.0MM SQ,250V/10A,2.5 METER,RTANG,IEC320,RCPT,CHINA	TK6253	92-2637-250BKH	
Adapter	103-0434-00			1	ADAPTER, USB A FEMALE TO USB B FEMALE		103-0434-00
Manual	071-1063-02			1	MANUAL,TECH:USER,TDSUSBF	TK2548	071-1063-02
Mini-B Adapter	131-7922-00			1	CONTACT, ELEC; DO-4 & DO-5 THD END CU BE GLD PL	80009	131-7922-00

